



## WebCarousel™ R&S DTVCAR

### Software for cyclic broadcasting of files

- ◆ For use in digital data broadcasting systems
- ◆ Runs on data inserters for DVB and DAB
- ◆ Broadcasting of any type of file
- ◆ Utilization of IP technology
- ◆ Combinable with MHP ObjectStreamer and MOTStreamer for DAB
- ◆ Easy administration of the content to be broadcast
- ◆ Content combination from all types of sources
- ◆ HTTP- or FTP-based content update
- ◆ Parallel operation of several carousels as NPAD
- ◆ Use of the Internet/intranet as a data delivery network



**ROHDE & SCHWARZ**

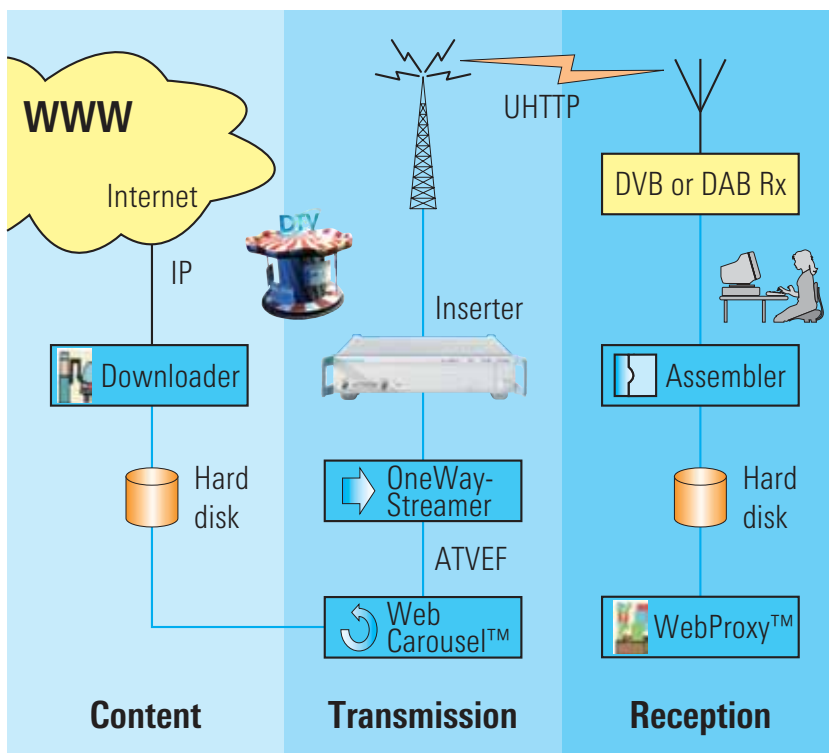

## Features

New data services (data broadcasting, DBC) are expanding and enhancing the digital broadcasting systems (DVB/DAB<sup>1)</sup>). In particular, the capability to receive services under mobile conditions ensures that the information matches the local circumstances and the needs of the users.

The WebCarousel™ is used primarily to combine Internet-based networks as well as their tools with modern digital transmitter systems in order to transmit data services.

The WebCarousel™ is an add-on used in conjunction with data inserters for DVB and DAB. It enables broadcasting systems to benefit from new data applications, and full services can be implemented. Files containing any type of information (databases, programs, games, websites, sound and video files) are cyclically transmitted.

The WebCarousel™ on the transmitting end is complemented by the WebProxy™ on the receiving end. Both tools can distribute complete file structures.

The WebCarousel™ as a server service transmits selected files (e.g. web contents) via digital broadcasting networks to stationary or mobile users, who can then view the websites by means of a common web browser. The files can be processed as necessary in computer-based receiving devices.

The WebCarousel™ can be used in combination with streaming media (MPEG4 videos, MP3/MP4 sound streams) to broadcast announcement files in addition to the IP streams.

Data transmission is an auxiliary service operating in parallel with a TV or sound broadcast program. The documents and files are transmitted by means of push technology. In broadcasting, unidirectional transmission is standard. The contents that are broadcast can be selected

from a play-out manager on the transmitting end and via filters on the receiving end. Back channels can be integrated into the system to control the data servers, but they are not an essential part of the product. A logical link between broadcast programs and data services is possible if the applications are appropriately configured.

The WebCarousel™ transmits its data cyclically, i.e. without being prompted. Content can thus be updated and modified at any time as well as at regular intervals. Push technology is comparable to teletext in function, which also makes it suitable for implementing supplementary text-based and graphical information (electronic program guides, EPG).

By using the Internet protocol (IP), content can be unicast (individual receivers) or multicast (receiver groups). Several carousels can be set up in parallel, for example, to transmit important files at a high repetition rate, while another carousel transmits files that are infrequently required. Thus, the available bandwidth for datacasting applications can be flexibly partitioned.

Files are transmitted cyclically because the information should always be available to every user.

The HTTPLoad or FTPLoad tools update the contents. Whereas HTTPLoad cyclically and automatically retrieves the data to be updated from a web server, FTPLoad is used to transmit new data and files from a PC (client) to a data inserter (server).

A streamer segments the information contained in the WebCarousel™ files into individual data packets which are then routed to the data inserter. After the packets are inserted into the transmit signal, which may already contain programs,

<sup>1)</sup> For explanations refer to page 5.

the transmitter broadcasts the entire multiplex (DVB) or the ensemble (DAB).

Various streamers are available for the different applications and can be connected to the carousel data source:

The **OneWayStreamer** transmits data as IP packets in accordance with the standardized multiprotocol encapsulation procedure (MPE, ISO/IEC 13818-6 standard). The standardized ATVEF protocol for carousels ensures reliable file transmission. For additional protection of the DVB or DAB transmitter system, a further error correction mechanism detects and partially rectifies transmission errors. Moreover, the ATVEF protocol allows WebProxy™ data exchange so that the number of files to be transmitted and the number of cycles necessary to achieve correct reception can be defined.

The **ObjectStreamer** inserts and transmits MHP objects (MHP play-out, standards TR 101 202, TR 101 812).

The **MOTStreamer** can be used to transfer multimedia objects (MOT) in DAB systems (standards EN 301 235, EN 300 401).

The WebCarousel™ includes the following software components:

- ◆ HTTPLoad
- ◆ FTPLoad
- ◆ Carousel
- ◆ OneWayStreamer
- ◆ ObjectStreamer
- ◆ MOTStreamer
- ◆ WebProxy™

## HTTPLoad

The contents and files to be transmitted by the WebCarousel™ are specified in the form of a text file. This file includes the server and intranet/Internet addresses (URL) with the storage location of the

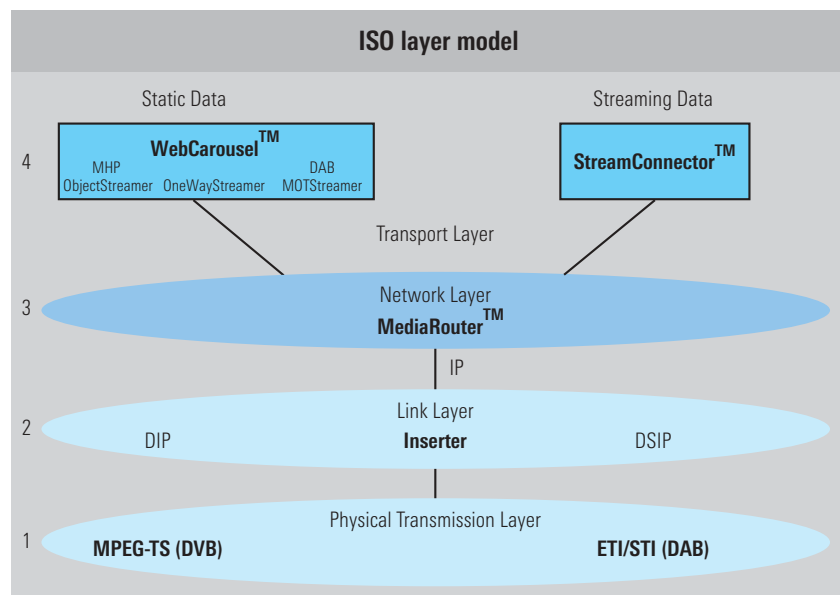

original files and is specified via a web address (URL) so that the user can locate it in the network.

The system administration is not permanently configured or tied to a specific PC, but can be operated from any PC in the network.

To simplify the maintenance of file name lists, the addresses can be shortened; if the name of the domain is specified, all associated and visible resources are broadcast.

When the control file is processed, all resources are copied locally. The user can define the period of time during which the locally stored files are matched to the original files in the network.

The administration of data to be transmitted (provided as a control file) as well as the broadcast content itself can both be distributed across computer networks. The intranet and the Internet can be used as platforms for the generation, administration and insertion of data into the broadcast system.

## FTPLoad

New or updated files can be transmitted from an FTP client to the data inserter (server). Several FTP connections can be operated in parallel; access control is via the FTP standard login functions. In the case of FTPLoad, the data is updated in parallel and without affecting transmission; synchronization with the carousel is possible, allowing automatic switchover to the broadcasting of modified or new files.

## WebCarousel™

The WebCarousel™ cyclically transmits the locally stored data. The throughput time depends on the available data rate of the data service within the broadcast signal and the data quantity. Each resource and each file is transmitted once during a throughput cycle.

The WebCarousel™ acts as a data source for different data services. Each carousel is therefore assigned to an individual streamer. Depending on the application, the following streamers are available: UHTTP Streamer, ObjectStreamer (MHP) and MOTStreamer (for DAB); it is also

possible to combine several pairs of carousels with one streamer each.

### OneWayStreamer

The data which is provided in file format by the WebCarousel™ is segmented into individual packets by the OneWayStreamer, matched to unidirectional transmission and transferred to the data inserter as IP packets.

A back channel is not necessary. Local interaction on a terminal is possible within the *walled garden*.

Primarily, the standardized UHTTP protocol of the ATVEF is used to transmit web-sites.

### ObjectStreamer

Objects for the multimedia home platform (MHP) are transmitted by means of the ObjectStreamer. For this purpose, the MHP objects are inserted (in accordance with the object carousel standard) and the required service information tables are generated and transmitted. This is handled by an MHP play-out since the complete MHP objects are routed to the inserter and are then automatically inserted and transmitted.

MHP can be implemented as program-associated data (PAD) together with non-program associated data (NPAD) on one and the same inserter.

### MOTStreamer

The MOTStreamer supports the multimedia object transfer in DAB applications.

### WebProxy™

The WebProxy™ is the counterpart of the WebCarousel™. Its components process data received via the broadcast system as IP packets to restore the original files. The received files are stored in local mass storage (cache). If transmission errors are detected, they can be corrected during the subsequent cycles.

The WebProxy™ also acts as a local web server to search within the local cache for web resources required by Internet tools (e.g. web browser) and to provide these resources for the tools.

The user is able to access the data as usual via the web browser. An online connection can be set up if resources are insufficient or if addresses lead directly to the network. If the network is accessible, back channels are implemented or complementary resources are requested.

As part of the receive card and software, the WebProxy™ is connected to the products of the terminal manufacturers (bundle); Rohde&Schwarz provides it free of charge and does not require a license. If necessary, the program source text can be licensed for further development, porting or modification.

### System requirements

The WebCarousel™ and its components (with the exception of WebProxy™) are directly installed and executed on data inserters at the transmitter end such as the R&S DIP010/020 or the R&S DSIP020.

A permanent network connection is not required since external data sources need only be accessed to store and update the contents via HTTPLoad or FTPLoad. This makes for highly efficient DBC play-out solutions.

The data inserter from Rohde&Schwarz comes factory-set with a functionally limited version of the WebCarousel™ which can be changed at any time to the full version by means of a software license key without requiring a new installation of the software.

Structure of WebCarousel™ solution

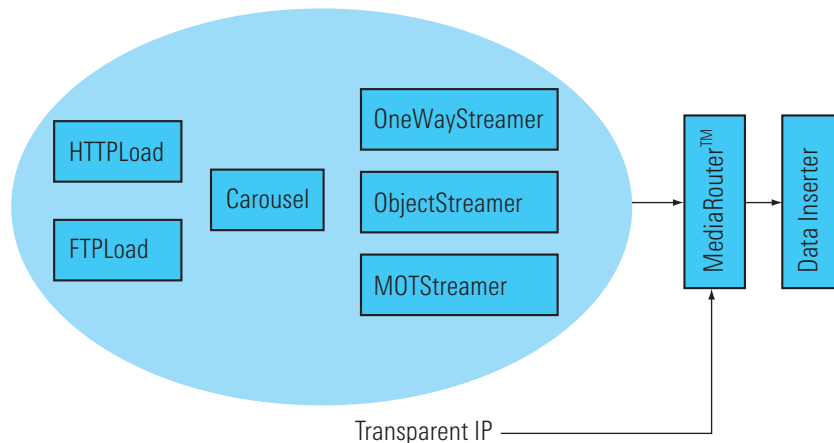

Prerequisites for the reception of the data broadcast by the WebCarousel™ are a suitable card as a PC extension, a set-top box or a DVB or DAB receiver. The receiver must support the extraction of the inserted data.

In addition, the MediaRouter™ comprises a QoS (quality of service) module to ensure the integrity of bandwidths and the throughput of data services.

The StreamConnector™ is used instead of the WebCarousel™ if streaming media contents (live data, videos and sound) rather than files are to be transmitted.

## Complementary components

The MediaRouter™ is the key component for parameterizing and configuring the DBC system. It provides great flexibility in coupling, setting up and modifying any services, and the services can be handled independently not only of each other but also of the physical broadcast systems.

## Abbreviations

ATVEF	Advanced Television Enhancement Forum
DAB	Digital audio broadcasting
DBC	Data broadcasting
DVB	Digital video broadcasting
MHP	Multimedia home platform
MOT	Multimedia object transfer
NPAD	Non-program associated data
PAD	Program associated data
UHTTP	Unidirectional hypertext transfer protocol

## Ordering information

Order designation	WebCarousel™	MHP ObjectStreamer	DAB MOTStreamer	WebProxy™
<b>Type</b>	R&S DTVCAR	R&S MHPCAR	R&S MOTCAR	R&S DTVPROX
<b>Order No.</b>	3540.9960.00	3540.9902.00	3540.9925.00	3540.9977.00
<b>Application</b>	DVB/DAB transmission	DVB transmission	DAB transmission	DVB reception
<b>Content</b>	Files	MHP objects	Multimedia objects (MOT)	Files, web content
<b>Components</b>				
HTTPLoad	x	x	x	
FTPLoad	x	x	x	
Carousel	x	x	x	
Streamer	OneWayStreamer	ObjectStreamer	MOTStreamer	

Order designation	Type	Order No.
MediaRouter™	R&S MEDIAR	3540.9931.00
StreamConnector™	R&S STREAMC	3540.9948.00



More information at [www.dbc.rohde-schwarz.com](http://www.dbc.rohde-schwarz.com) or [www.datacasting.rohde-schwarz.com](http://www.datacasting.rohde-schwarz.com)



**ROHDE & SCHWARZ**

ROHDE & SCHWARZ FTK GmbH · Wendenschloßstr. 168 · 12557 Berlin, Germany · Tel. +49 30 65891-103  
www.rohde-schwarz.com · Fax +49 30 65550221, E-mail: Hotline.Ftk@Ftk.rohde-schwarz.com